

M57719

145~175MHz, 12.5V, 14W, FM MOBILE RADIO

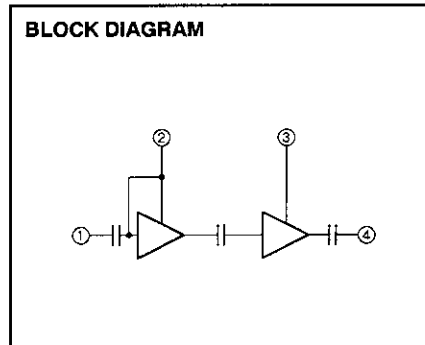
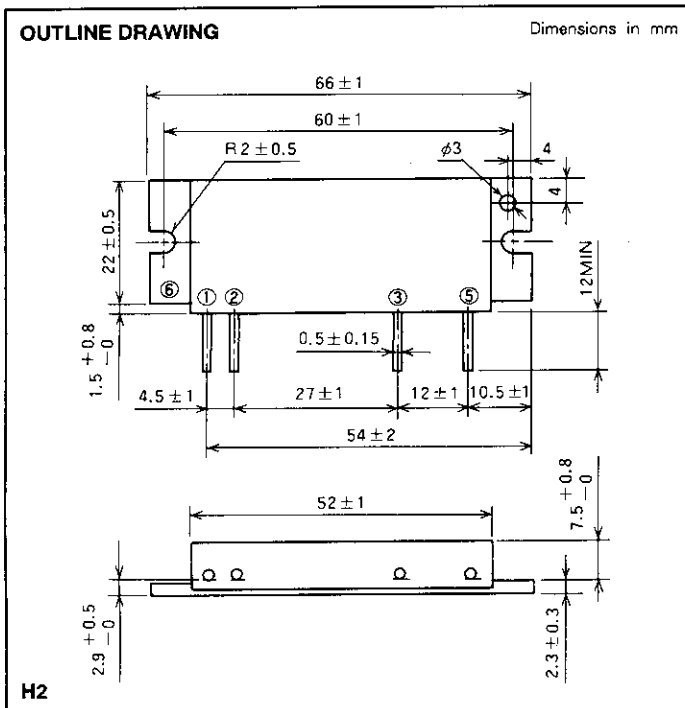

- PIN :
- ① Pin : RF INPUT
 - ② Vcc1 : 1st. DC SUPPLY
 - ③ Vcc2 : 2nd. DC SUPPLY
 - ④ Po : RF OUTPUT
 - ⑤ GND : FIN

ABSOLUTE MAXIMUM RATINGS (Tc = 25 °C unless otherwise noted)

Symbol	Parameter	Conditions	Ratings	Unit
Vcc	Supply voltage		17	V
Icc	Total current		6	A
Pin(max)	Input power	ZG = ZL = 50 Ω	0.4	W
Po(max)	Output power	ZG = ZL = 50 Ω	20	W
Tc(OP)	Operation case temperature		- 30~110	°C
Tstg	Storage temperature		- 40~110	°C

ELECTRICAL CHARACTERISTICS (Tc = 25 °C unless otherwise noted)

Symbol	Parameter	Test conditions	Limits		Unit
			Min	Max	
f	Frequency range	Pin = 0.2W Vcc = 12.5V ZG = ZL = 50 Ω	145	175	MHz
Po	Output power		14		W
ηT	Total efficiency		40		%
2fo	2nd. harmonic			- 25	dB
3fo	3rd. harmonic			- 35	dB
ρin	Input VSWR			4	-
-	Load VSWR tolerance	Vcc = 15.2V, Po = 14W (Pin : controlled) Load VSWR=20:1 (All phase), 2sec. ZG = 50Ω	No degradation		-



30835